

Cleaning Technology · Municipal Technology

Hako

Clean ahead



Citymaster 600

*Multifunctional vehicle and sweeper –
no need to compromise!*

The Citymaster 600 – for professional and economically efficient working

Compact and universal – the industry's champion



“Powerful, robust and manoeuvrable – just the way it should be”!



“Quick changing of attachments for maximum flexibility”



“Increased coverage and fewer empty runs”.

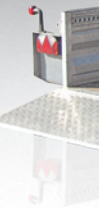

And what can the Citymaster 600 do for you?

The pro in the compact class

It is your aim to carry out reliable work and to satisfy your customer's needs in the long run! What you are looking for is a professional, powerful and versatile implement carrier, right? The Citymaster 600 meets your demands exactly – with best-possible operating comfort and innovative quick-change system for a range of attachments designed to suit your individual requirements. Hako's years of experience in the field of compact tractors and sweeping machines are all concentrated in this one machine – use it to your advantage!

New dimensions of economic efficiency

The Citymaster 600 combines multifarious advantages and functions with compact dimensions while the driver's spacious and comfortable workplace facilitates long working days. With its small working width and extreme manoeuvrability, the vehicle can access even the most confined areas. The all-in-one universal implement carrier with a quick-change system and plenty of different attachments – that's what we call cost-effective. You only buy what you really need. In the long run, the robust and maintenance-friendly design makes the Citymaster 600 profitable. Hako quality pays off quickly. If you are interested in our flexible financing options, simply ask your local Hako sales & service partner for further information!

The sophisticated vehicle concept made "by professionals for professionals"

A small space full of big advantages

1

Fast transport

Fast enough to reach a nearby job site under its own power. Suitable for trailer transport for longer distances.

2

Detailed multi-functionality

The universal high-strength aluminium hopper can be used for sweeping or lawn mowing but can also be utilized as an extended water tank – at maximum load capacity.

3

Increased flexibility

The robust implement carrier with its compact dimensions and versatile attachments is perfectly suited for flexible employment even in confined areas.



The multi-functional narrow-gauge implement carrier

The machine from the operator's point of view



Extremely manoeuvrable

Compact dimensions, directionally stable steering and the small turning radius ensure excellent manoeuvrability in confined areas.



The concept

The Citymaster 600 takes you everywhere but never reaches its operational limits. Thanks to its true track articulated steering, the vehicle is easy to manoeuvre even in narrow areas. The chassis integrated float compensation keeps the vehicle on track to ensure safe driving even with heavy loads and provides high levels of manoeuvrability and flexibility both in open terrain and on curbs. The automotive permanent all-wheel drive ensures fully-controlled power throughout the entire speed range. The robust construction, designed for professional use, guarantees a long service life and keeps the vehicle's value. The basic model is equipped in a manner that provides for easy upgrading to the full functional operation of a professional sweeping machine. Robust technology – made in Germany!

Operation and comfort

The Citymaster 600 is made for its operator. Everything has its place and is within easy reach and view. The big windows of the ROPS-tested safety cabin allow an excellent view of the work area. The one-hand operation panel is installed in the driver seat's arm rest, the adjustable vehicle data display and low noise level guarantee that the driver can safely concentrate on his work. The efficient heating system and optional air conditioning ensure comfortable working in all seasons. Two full-size doors enable safe exiting on both sides.



Spacious

Cabin with ample headroom, hot-water heating system with optional air conditioning, different air jets with footwell heating. Switch for additional functions in the roof console.

Ergonomic



Overview

The high-definition colour display provides an excellent overview of the operating status and the machine parameters.

Functionality

The one-hand-operation joystick is integrated in the arm rest, the turn-push regulator and the function switch ensure that the driver has all the different functions under control.

Handy

The most important basic functions are integrated in the individually adjustable steering console, all within easy reach of the driver. For safe handling and an excellent view.

Comfortable

Safe



Farseeing

Big cabin windows, a lighting system with integrated work light as a standard and an optional rear view monitor ensure a panoramic all-round view for increased safety.

Convenient

Large-size, comfortably aligned universal tyres allow employment on every kind of surface. Ground-protecting wide base tyres are optionally available for employment on lawns.

Comfortable

Both the suspension seat and the air-sprung comfort seat (optinal) have plenty of adjustment settings. Demand meets diversity – and an operating panel comfortably integrated in the arm rest.

Uncompromising multi-functionality



- Sickle mower (mowing, mulching, collecting)
- Mallet mower
- Hedge trimmer



- Snow blade (fully hinged, spring-hinged, V-plough)
- Front sweeping machine
- Snow blower



- Sweeping unit
- Front sweeping machine
- Water-spraying bar
- Weed broom



- Universal hopper
- Water tank
- Loading bed

• Trailer

- Cylinder spreader
- Combi spreader

Quick-change attachment system

The most important quality of an implement carrier is its versatility. The new quick-change system offers four mounting interfaces designed for easy, tool-free one-man operation. The new quick-change coupling triangle at the front enables extra-easy change of equipment and is fully compatible with older attachments. The suction device interface enables not only winter employment with full ground clearance but also mowing plus grass collection and fully functional sweeping with suction duct, coarse dirt flap and (circulating) water system. Rear attachments are mounted with a quick-change frame which can easily be removed by using a trolley. The rear mounting frame allows for the attachment of additional accessories.

Transmission

The compact Citymaster 600 also scores right down the line in terms of low fuel consumption, RPM, emissions and noise levels, ensuring economically efficient employment.

The automotive drive ensures lowest possible fuel consumption during road use and optimal adjusted performance in any given situation with three different work mode power levels (ECO, Standard, MAX).

The ECO mode supplies 85% of the overall power to feed the attachments – enough for most maintenance jobs.

The other two performance levels offer sufficient reserves for tougher jobs.



Hydraulic system and steering

The hydraulic system with well-arranged, easily-accessible couplings enables the universal connection of attachments. Two independent circuits, supplemented by up to two additional operating circuits at the front (rear: one circuit), feed the attachments. Each of the machine's individual functions is comfortably controlled by the one-hand operation panel integrated in the arm rest. For complex tasks such as employing the sweeper attachment, the hydraulic system controls the functions fully automatically at the touch of a button – for safer and smoother working.

Fleet management for even more economic efficiency

Hako offers tailor-made fleet management solutions for efficient machine employment. The Hako fleet recorder provides transparent up-to-date fleet data automatically. The Hako fleet report offers an overview of any contractual work carried out on the machine. The data is retrieved via PC or mobile smart phone.

1) Front coupling triangle

for easy and universal changing of attachments

2) Rear attachment mounting frame

for spreaders, trailers or counterweights

3) Rear body-mounting system

for easy changing of attachments with a trolley

For gardening & landscaping



Variable employment, large coverage

Systematic mowing

The Citymaster 600 makes ground maintenance easy. The multi-talented machine carries out variable employment in combination with different mowing units, grass collecting systems or mallet mowers. Exactly the kind of economic efficiency required in gardening & landscaping. A sickle mower with a working width of 1.22 metres, which can be utilized as a rear discharge or mulch mower but also as a grass collector, is available for sophisticated ground maintenance tasks. A sickle mower with a working width of 1.30 metres is available to take care of extensive areas.

Lawn-mowing/vacuum combination

The universal hopper of the Citymaster 600 can also be used for lawn-mowing purposes. The central vacuum system enables working close to borders on both sides. The vacuum suction is both quieter and more efficient than conventional vacuums – and basically wear-free. In conjunction with the short, straight and central vacuum path through the vehicle, downtimes due to blockages are reduced to a minimum. The hopper capacity is particularly efficient – for extended emptying intervals and an increased payload. The high-dump enables dumping on the ground in several layers as well as the tipping of containers with 1.30 metre side plates.

The Citymaster 600

For winter services



All-round vehicle for winter services!

The Citymaster 600 is all set for winter employment. The comprehensive range of winter equipment enables universal all-year-round use. Once again, the excellent manoeuvrability and easy handling effectively show what the vehicle is capable of. The compact dimensions and a transport capacity of 400 kg salt & grit ensure long periods of operation.



Flexible front-mount system

All set for every kind of employment: reliable snow-sweeping with the front-mounted sweeping unit or snow clearing with a snow plough or snow blower.

Tackling icy roads and paths

No skidding: with rotary spreader for footpaths, combi-spreader for larger areas or brine spraying system.

The Citymaster 600

The professional sweeping machine



The star in terms of particulate emission

Approved by highest possible ranking in EUcertified PM 10 Test.

Compact sweeping performance

Professional sweeping results

Considering its compact dimensions, the Citymaster 600 is a high-class performer. The integrated professional sweeper including big adjustable brooms and a powerful suction unit enables large-scale cleaning. The universal hopper with a nominal volume of 600 litres and a loading capacity of 500 kg ensures wide-range coverage and a long, efficient period of operation. The robust design of the professional sweeping unit features a number of gadgets protecting the vehicle against damage. Both the quick-change system and the tripod enable the quick & easy mounting of the sweeping unit and hopper – no additional personnel are required. The high-dump as well as easy cleaning after work save both time and money.

Environmentally-friendly equipment

Great performance is something you want to see – not hear. That's why you can switch to ECO mode while the machine is in sweeping operation to reduce both the fuel consumption and noise emissions. The sophisticated water system consisting out of fresh and recirculation water has maximum dust-binding qualities and cleans the exhaust air. The exhaust air is silently fed over the hopper lid to protect the environment as well as pedestrians. Useful extras such as the hand-held suction hose and the high-pressure cleaner add to the range of applications in road and footpath cleaning.

Convincing technical data

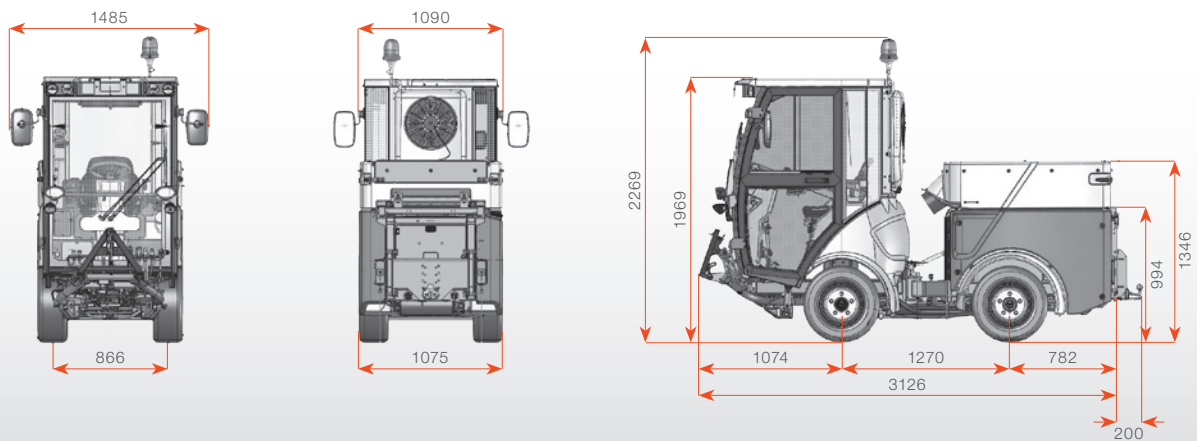

Technical data basic vehicle Citymaster 600	
Engine and Transmission	
Engine	<ul style="list-style-type: none"> • Water-cooled 3-cylinder YANMAR diesel engine with 1,642 ccm • Power output of 27.1 kW at 3.000 rpm, adjusted to 24.2 kW at 2,600 rpm • Direct fuel injection, 41 litre tank volume • Engine is below the limit values complying with the European Exhaust Emission Standard 97/68/EG Stage IIIa
Approval	<ul style="list-style-type: none"> • EU type approval, basic machine as tractor
Drive	<ul style="list-style-type: none"> • Hydrostatic drive with permanent all-wheel drive • Drive control with automatic load regulation in transport mode • 3-level constant speeds (ECO-Standard-MAX) in working mode
Hydraulics	<ul style="list-style-type: none"> • 2-circuit high-pressure hydraulics 195 bar • Circuit 1 27–37 l/min • Circuit 2 21–29 l/min • 2 hydraulic operation circuits, additionally 1 x electronically reversible at the front
Driving and Work Characteristics	
Speed	<ul style="list-style-type: none"> • Driving speed, automotive 0–25 km/h • Working mode, hydrostatic 0–25 km/h • Reverse mode 0–12 km/h
Chassis and Steering	<ul style="list-style-type: none"> • Hydraulically articulated 4-wheel chassis, tubular steel, steering angle 53° • Integrated and damped floating axle compensation for optimal curb climbing ability
Brakes	<ul style="list-style-type: none"> • Hydrostatic brakes via transmission • Additional mechanic service- and parking brake via foot pedal
Tyres	<ul style="list-style-type: none"> • 23 x 8.50 – 12 (standard tyres) • 23 x 10.50 – 12 (lawn tyres)
Cabin	<ul style="list-style-type: none"> • Single seat comfort cabin with comfort driver's seat, operating panel integrated in the arm rest • Central display showing all of the machine's functions, adjustable steering column • Hot water heating and optional air conditioning • Framed doors with sliding windows • Folding wing mirrors, adjustable from inside
Load values	
Deadweight	1,350 (implement carrier), 1,700 (sweeping machine)
Permissible total weight	2,200 kg, permissible axle load 1,200/1,500 kg (front/rear)
Dimensions	
H/W/L	Basic machine: 1,969 mm (cabin) x 1,090 (cabin)/1,075 mm (standard tyres) x 3,126 mm
Wheelbase	1,270 mm
Track width	866/926 mm
Turning radius inside	700 mm

Alterations in form, colour and design are subject to change in favour of further technical development. Images may contain optional extras.



Hako: environmental-friendly right from the start

It is our legacy to leave behind a clean planet. That is why resources-, environmental- and climate protection characterize each and every process at Hako which has been certified by independent institutions. Learn more about our on-going commitment at www.hako.com

Close to you wherever you are

Our efficient close-knit sales & service network guarantees close proximity and rapid help.

Cleanliness combined with safety

Our machines meet the highest standards. Reliable quality "Made by Hako".

Buying, leasing, renting

We offer you a number of individual and attractive financing & procurement options.

We are available 24/7

Hako's spare part express- and on-call service guarantees best possible availability.

BLUeCOMPETENCE

Alliance Member

Partner of the Engineering Industry Sustainability Initiative



DIN EN ISO 9001:2008
DIN EN ISO 14001:2009

Hako GmbH
Head office
Hamburger Str. 209-239
23843 Bad Oldesloe
Tel. +49(0)4531-806 0
info@hako.com
www.hako.com